

## Microwave Newsletter 03-81

Reports and information for the next issue should be sent to J. Gannaway, 17 Crick Rd, Oxford before the 5th May. Anyone else who wishes to receive the newsletter should send 3 (for 10 issues, 1 year), to RSGB HQ, marking the envelope "Microwave Newsletter".

### GaAsFETS

G4FRE has received some GaAsFETS from the firms in the States mentioned last month; an MGF1400 took 3 weeks to arrive and cost \$23.5, plus \$4.5 for postage. Now that GaAsFETS are available at reasonable prices, they should greatly improve the performance of UHF equipment.

### Operating News

#### 1296 Activity nights

There is an activity night on 1296MHz every Tuesday from about 8pm local. So far, the activity has mainly been from the East Anglia area and a few PAO s, but we hope it will spread further afield.

G3FYX had successful two way tests with GW3PPF and GW8NBK on 3.4GHz, and a one way on 10GHz narrowband over a 49km path from Tost? hill to Cardiff. He also has some 5.7GHz gear, a BXY28 in a G3WJG multiplier and filter, and a DC3QS mixer from VHF Comms (Spring 1980 ) which seemed to tune up quite easily. He is looking for some WG14 for an aerial feed.

### Rain Scatter on 10GHz

During a recent QSO between G8ADP and G3YGF, there was a heavy rain storm at G8ADP. While it was actually raining, signals were very rough, and about 10-20dB above the normal troposcatter level. The interesting thing was that signals were the same strength whichever direction Clive beamed, and also when his reflector plate was set vertically, so that his dish was just pointing straight up into the rainclouds. The beam heading at G3YGF was its normal narrow value, though signals could be heard at elevations of 5-8 degrees. The rain cell was presumably scattering signals in all directions from heights of up to several thousand feet. The path from this cloud to G3YGF would then have been line of sight. This would enable stations to operate from very poor home locations by pointing a relatively low gain aerial at very local rainclouds. Whilst heavy rain does attenuate signals over line of sight paths, do not overlook the enhancements it can provide over obstructed paths.

## 10GHz Narrowband Equipment

G3PFR has built a 10GHz narrowband source using a Microwave Modules oscillator source into a Wood and Douglas 3W PA and the G8DEK multiplier. 500mW from the MM gave 4W from the PA. He says the output spectrum is quite clean, although he has not yet listened to the note. They were very straightforward to align, and he would recommend them to people with limited test facilities. He also has some comments on the method of aligning the G3JVL mixer cavities by observing the reflected power. The first cavity should dip the reflected power, the second peaks it, and the third dips it again. This may be rather unexpected, but is in fact correct, and has been checked by using a small probe into the next cavity through the hole for the tuning screw. He also emphasises that resonance will not be obtained unless the screws are very clean and a tight fit in the nuts. This can be ensured by keeping a gentle torque on the locknut while the screw is being adjusted. He wonders if the use of dielectric tuning screws might overcome this problem, and is looking for a source of PTFE 6BA screws. (I have just tried some nylon screws to tune the cavities and they do work, needing to penetrate slightly further into the cavity, than brass ones, but they do increase the loss from about .8dB to 3.2dB for a 60MHz wide filter. PTFE may well be less lossy - G3YGF).

## Microwave Committee 384MHz oscillator boards

GM3FYB suggests replacing R9 by a 1k pot, to give control of output from 0 to full value (350mW in his case). In some earlier versions, R22 was given as 15ohms. This can lead to the PA getting excessively hot whilst only slightly increasing the power output. A value of 22 or 27 ohms is recommended.

G3NAQ built the modified G3JVL mixer by cutting out the waveguide wall. He had no problems tuning up the 384MHz oscillator board to give 170mW, and obtained of 3-4mA diode current into a waveguide mounted detector diode from the multiplier, and then immediately saw a few microamps of mixer diode current when the multiplier was coupled to the mixer assembly (a very sensitive current meter helps - G3YGF), and was able to optimise this to 5mA. He is currently in Geneva, but hopes to be operational soon.

G4FRE has found that the Birkett BGY22C although specified as 420-480MHz can still give 2W at 378MHz. He has also done some measurements on the 384MHz oscillator board, and says that the PA keying circuit only reduces the output by 13dB. (I would not recommend using this for A1 keying though, as the frequency does pull slightly, and F1 would be a much nicer method of keying it - G3YGF).

G8SHF reports some measurements of power density 5 cm from an open X band w/s flange running 100mW as being 2-3 mW /sq cm. This was done with professional measuring equipment, and the values obtained agree well with calculated values. This illustrates that high power need not be a hazard, provided one keeps a sensible distance from the obvious regions of high power density.

G3YJH has moved, his new address is 28 Cartersfield lane, Stonnall, Nr Walsall, WS9 9EF.

## Contests

The Alpha cup will be awarded to the winner of the cumulative contest this year. There will also be a certificate for the leading station using low power wideband equipment (see the Microwaves column for details).

## Expeditions

G4FRE hopes to be going to Belgium in August with equipment for at least 10GHz, wide and narrow band.

GBAFC is planning to go to EI (Wicklow Mts) with 10GHz wide and narrow band equipment, 144MHz, 432MHz, 1296MHz, and Polarflexers for 3.4GHz during the 23-30 May. Callsigns used will be EI2VDD, VDE, VDF. Skeds will be most welcome, contact GBAFC, QTHR. 061-865 3183.

#### Beacons

GB3SWH: The latest information is that it is being tested from someone's home QTH. It is hoped to have it operational from its proper site in the next two or three weeks.

GB3LEX: GBFWA reports that the Leicester beacon is on, but the note sounds rather rough.

GB3NWK G8CIU reports that this beacon located at Chelsfield, near Orpington, will be switched on on the 18th April. It will be on 1296.810MHz running 10W to an 8 over 8 (approx 50W EIRP) beaming up the Thames Valley towards Oxford. Its keying sequence will be: "GB3NWK <QRA> Chelsfield".

GB3XGH: G3PFR has some details of the new beacon on 10GHz. Its location is YN67B, SJ 567721, 18k E Chester. The aerial is an omni-directional slotted waveguide with a gain of 15dB, and is at present 30ft asl at G3PFR's home QTH which is 300ft asl. It is running 16mW of wideband F2 using a modified GBAPP Gunn with an isolator on 10400MHz with the keying sequence: " de GB3XWH, tone " repeated every 30 secs at 12wpm. It has been operational since 1/1/81. The expected coverage is from Mow Cop to Winter hill, but from W to S it is badly screened by some local trees.

He hopes to move it to a better site in 1981, and to use a 50mW n/b source from G3TPW. Mike is very keen to receive any reception reports. He says that the worst part of it was making it really waterproof.

#### Sale or Wanted

##### Mixer and detector diodes

G3LQC has kindly agreed to supply mixer and detector diodes for X band; types: 1N415E, Si point contact, 7.5dB NF, 1N23 type pin ended package  $\frac{1}{2}$ 1-35; DDB6224, Si Schottky, 7.5dB NF, low audio noise for motion detector applications, 1N23 type package,  $\frac{1}{2}$ 1-35; and a mechanically rusedised version of the 6724 for  $\frac{1}{2}$ 1-53. Orders CASH WITH ORDER to Mr. R. Evans, Alpha Industries, RMC House, Station Road, Witney, Oxon.

GBADF offers a 6ft high 19" ex PO rack, free to anyone who can collect it! Also a pair of 50mW Klystrons (CV2346), each with a cavity tuned by a large micrometer calibrated in lambda from 2.8 to 4 cms at  $\frac{1}{2}$ 7.50 each. A 9cm wavemeter, W1633 calibrated 8 - 11 cm, with calibration graph for the 9cm band. WG22 bits: 6 bends, 2 attenuators, cross couplers, 2 noise tube mounts, two 6inch lengths of twistable guide, 12 pairs of rings, all to be swapped for WG20 or WG24. An AVO 40 with 4.8kV multiplier  $\frac{1}{2}$ 10. Several X band wavemeters with Moore and Wright micrometers coupled to a short piece of WG16. TWTs Watkins Johnson 1-2 and 2-4 GHz, self contained mains psu. 3 for  $\frac{1}{2}$ 5: 1 works, 1 does'nt, 1 untested.

G3FYX is looking for some WG14 to make a feed.

We apologise for the poor quality of the xerox of the tables of data on brass tubing last month. If anyone wants further information, contact one of the authors.

Change-over System

The change-over system below is as used by Dennis Morris, G3AYJ with his narrowband JVL mixer for 3cm operation. Besides the change over from receive to transmit on the mixer, the facility is provided to switch the 144 MHz tranceiver directly into an antenna for talkback. While it may still be necessary to retune when doing this, the operation of unplugging and plugging in leads is eliminated.

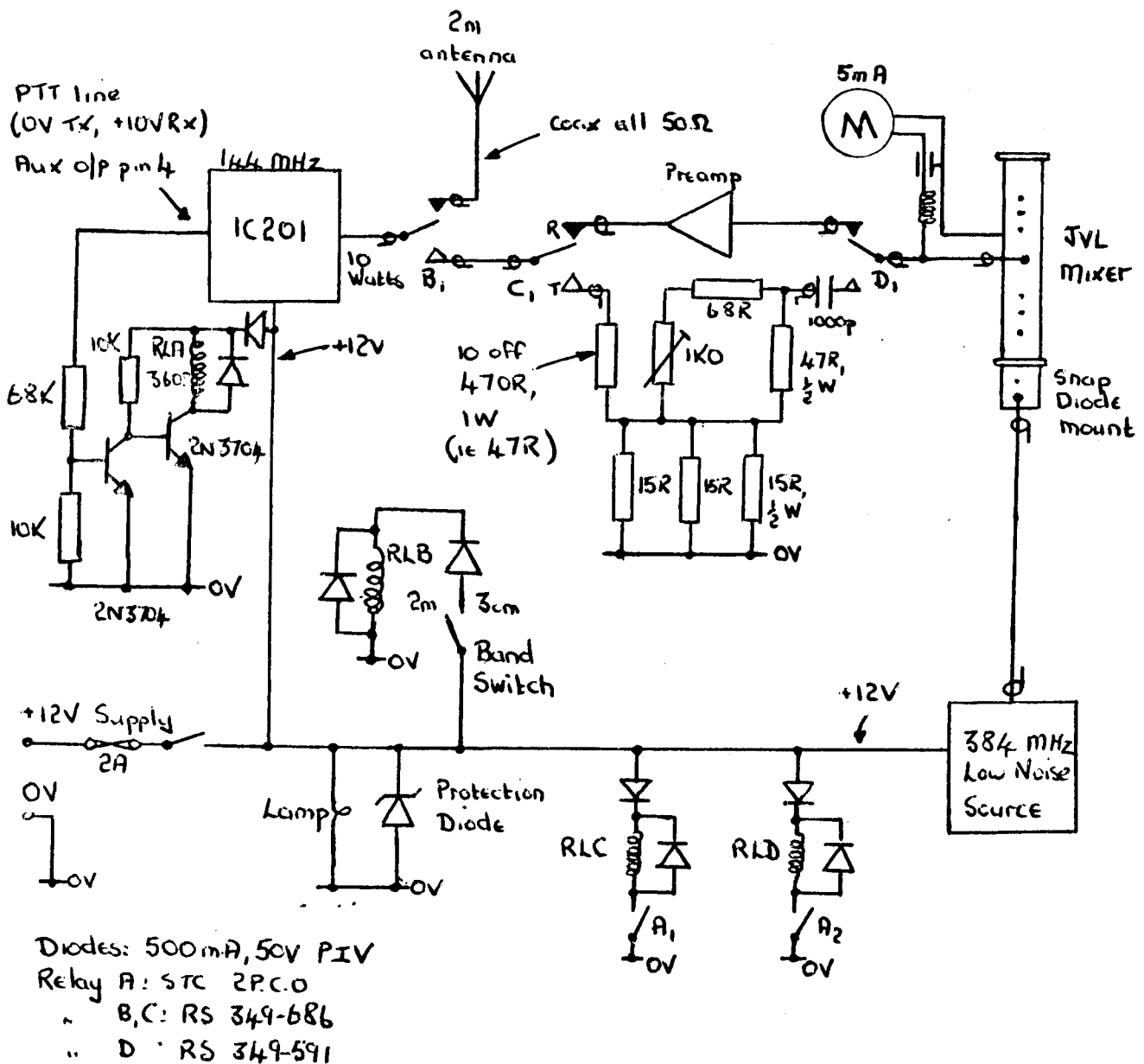

On transmit a power attenuator is switched into position when operating on 3cm, and a preamp is used on receive on 3cm. Note that the power attenuator will also be switched into position when operating directly on 2m, and also in the event of the PTT line being accidentally disconnected. It is not possible to have a 2m power output available without a supply voltage to the relay control circuits. The use of diodes in the positions shown is important for suppression of transient voltages.

13.5.81

04/81

### Microwave Newsletter 04-81 (May)

Please keep up the flow of operating news, comments, technical items and info. The deadline for next month's edition is 8th June and material should be sent to J. Gannaway, 17 Crick Rd, Oxford, or phone 0865-59988 ext 348 during the day.

#### Beacons

G4FSG reports that GB3BPO was off the air for about 2 weeks until the 1st May due to a fault in the control MPU. It is currently on with a temporary control system while the MPU version is being repaired.

G4FRE reports that GB3LDN (2.3GHz) was audible in Bedford during most of the contest weekend (2/3 May). He also heard GB3LEX (10GHz) from Bedford (30KM) just before the last cumulative.

G8BJG reports that due to problems with the varactor multiplier, GB3NWK was not able to be switched on at Easter as was hoped.

G3WDG and G4KGC have been listening for a beacon left on the moon by one of the Apollo missions. It is believed to be running about 1W into a 15dB ant, and transmits right hand circular polarization on 2276.000GHz. They have heard it on the 20ft dish at Oxford at about 10db S/N in 500Hz, and 0dB S/N on a 4ft dish, using a 2dB NF GaAsfet preamp. It is frequency modulated by data, and several of the fm sidebands spaced a few KHz apart are audible, pulsing at a few Hz rate. It should be a very useful signal source for testing and optimising receiving systems on. The signals will be 3dB weaker if linear polarization is used, however if you use circular, be very sure to get the correct handedness; if in doubt, try both!

#### Events

The East Suffolk Wireless Revival is being held on 24th May (see May Radcom). One of the items of interest is that there will be facilities for comparing aerial gains on a range at VHF and up to 2.3GHz. Contact G4IFF QTHR.

#### GaAsFETs

G4FRE sends some more details of the Mitsubishi GaAsfets available from Lunar as mentioned two months ago: MGF 1200, \$13; MGF 1400, \$23.5; MGF 1402, \$40.5; MGF 1412, \$61; MGF 1403 \$130. Dave has tried an MGF 1400 in the JA6CZD circuit and claims a 0.5dB NF.

02/04/81

#### Operating

G8SHF and G3FYX went to Pendeen Watch, Cornwall, for the last cumulative and tried a test with G3PPF and G8NBK up the west coast to Portpatrick on 10GHz from 1115 to 1730, but unfortunately conditions were not right, and nothing was heard.

On 16th April they managed to make a 154km super refraction path from Pembroke to the Mendips with G3PPF and G8NBK and Cliff now has his 150km award. 24GHz was also tried, but to no avail.

They also tried the path on narrowband, and while the 10GHz signals experienced considerable flutter around sunset, the 3.4GHz signal levels were quite stable. Does this suggest that any duct that existed were too small to affect the lower frequencies? Roy now has 5mW of cw or nbfm on 10GHz, as well as a G3JVL transverter.

G8ADP noticed the rain scatter effect( see last month) again on 3/5/81 when signals from G3YGF were as strong on open waveguide pointing vertically upward as they were when using his flyswatter normally. With the climate we have in Britain, this is proving quite a frequent mode of enhancement!

Due to lack of space in the car, G8AGN was only able to take out a 17dB horn, but from Ashley Heath, Staffs, SJ738365 he worked G3YJH/P, G8HMV/P at Titterstone Clee (61k), G3MWQ/P, G8VZT/P at the Wrekin, (30k), and G3PHO/P at Merryton Low(37k).

G4FRE was on during the UHF contest using the GB3BPO contest gear (25W and 2x47ele loop yagis) from Bedford. He worked 3 stations on 2.3GHz; G8ADC, G4BEL and G3RQZ(115km).

We note with regret the death of G2RY, who was active on 1.3 and 10GHz.

#### Talkback

In order to help reduce the QRM around .33, It is suggested that 144.33 be used only as a calling channel, and that people should QSY to 144.160 - 144.190 for working. This should give us a bit more room to spread out and have a clear talkback frequency. There also seems to be a mixture of horizontal (beams) and vertical (whips) polarizations being used; there are probably arguments for either standard, but this should be borne in mind when calling CQ on one polarization has become unsuccessful.

#### For Sale

G8ADP still has some X band micrometer tuned wavemeters mounted on waveguide with flanges for 3 each.

#### Technical

Some trouble has been experienced with the GDO33 Gunn oscillators as their frequency can be pulled quite badly by a changing load impedance. For the worst case loads, it can be pulled several hundred MHz; a 10dB attenuator reduces this to tens of MHz. In practice the load changes will not be this extreme, but objects moving in front of the aerial can still have a noticable effect. It might be possible to improve the stability by using an iris placed a number of half guide wavelengths from the diode as in the 10GHz designs.

03/04/81

G3PFR has tried a nylon screw instead of a PTFE one to tune a Gunn, and has found that it reduces the power output by 10dB and reduces the tuning range. This suggests that PTFE screws may well be useful for tuning the narrowband filters in view of the reasonable performance obtained from nylon screws quoted last month. Does anyone know of a source of them? Mike built two multiplier mounts and filters in a couple of evenings with only hand tools available - he hopes that his success will encourage others to have a go. We could do with a good crop of narrowband beacons!

G3JVL is back on 10GHz again after the winter gales took the reflector plate off his flyswatter system. The new reflector plate is slightly larger than the old one, but made from a wire mesh that is very much more transparent to the wind. He has done some experiments with several meshes, and found that galvanised wire mesh with half inch square holes has a very low wind resistance. For use on 10GHz it needs two thin enamelled wires threading along the mesh in each hole along the direction of polarization to make it suitably reflective.

G8KRD has suggested the following model shops as good sources of hardware: Allmodels Engineering, 91 Manor Way, Ruislip, Middx, for PTFE and nylon rod, 1/4" to 4" dia, and J.A.Crewe, Dawn Edge, Spinney Lane, Apsley Guise, Milton Keynes, for most metals and alloys in many forms.

73 de G3YGF G4CNV and G4KNZ

\* \* \* \* \*

Modifications to 384 MHz Source

Several people have had problems with bad chirp when using the original circuit for fsk. The following circuit is recommended as a much more satisfactory method of producing fm or afsk, as it does not alter the DC conditions around the oscillator. It operates by using a varicap diode to vary the capacitance across L1. The value of C2 must then be reduced to maintain the total capacitance at 27pF. The BB105B (C = 7pF at -5V ) with C2= 18pF should give a deviation of about 2kHz/V at 10GHz. Wider deviation could be obtained by using a higher capacitance diode such as the BB110G, or a hyperabrupt type which has a larger capacitance swing, eg the Alpha DKV6520.

Inputs are provided for audio at low impedance ( source impedance less than 1k), or cw where earthing the input shifts the carrier about 1kHz hf at 10GHz; the shift can be altered by changing the 47k resistor.

The components to the right hand side of the dotted line should be mounted directly across the tuned circuit. The rest can be mounted in place of the A1 keying circuit if this is not required, but in any case they should be mounted on the board to avoid earth loop problems. Efficient filtering is necessary on both inputs to prevent any stray af or rf noise causing unwanted sidebands on the output.

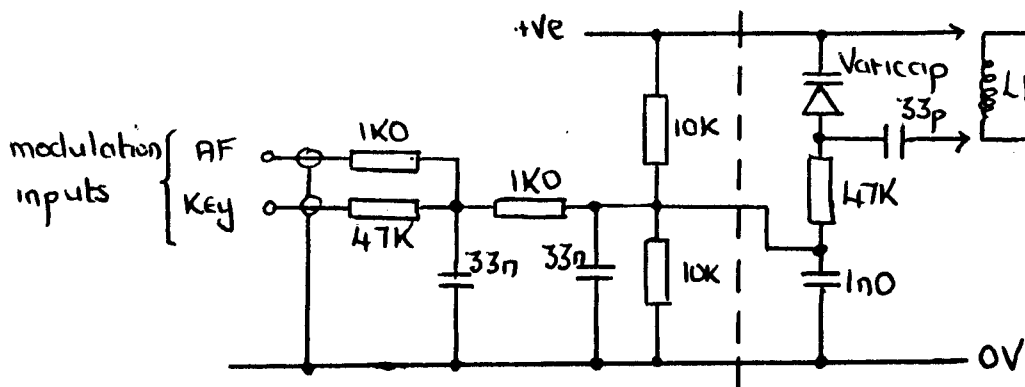

04/04/81

### Propagation

In the opening on Jan 31st, GW3PPF, located at Cardiff, was unable to exchange 10 GHz signals with stations in Dorset, while able to get into France. However on lower bands (up to 1.3 GHz), he was able to work both areas.

If this was due to the critical angle being exceeded at the top of the inversion layer on the shorter paths, this would in fact cause the lower frequencies to escape first. Thus Phil suggests that perhaps the 10 GHz propagation to France could be due to the formation of an elevated duct of small thickness, such that it is too small to propagate but able to reflect VHF and UHF frequencies.

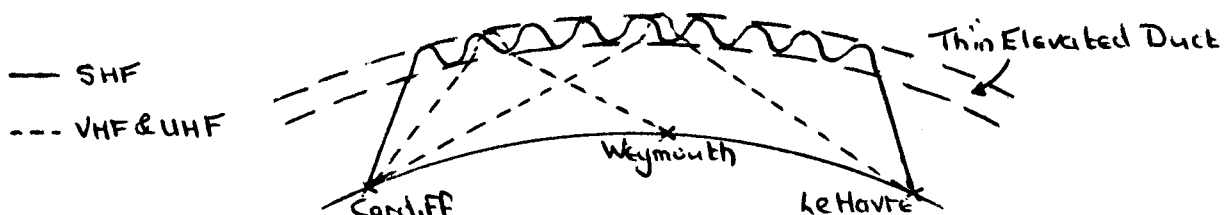

If this were the true propagation model, this would mean that the best paths to try during openings would be those coinciding with the maximum range obtainable on VHF and UHF, rather than shorter ones. Phil says he would be interested in other readers comments on the subject.

### Mic Preamp

The following is a circuit used by GW8NBK for feeding a 384 MHz source for NBFM. The output is connected to a filter mounted on the 384 board. No doubt the circuit could be put to use as part of a Gunn diode psu also.

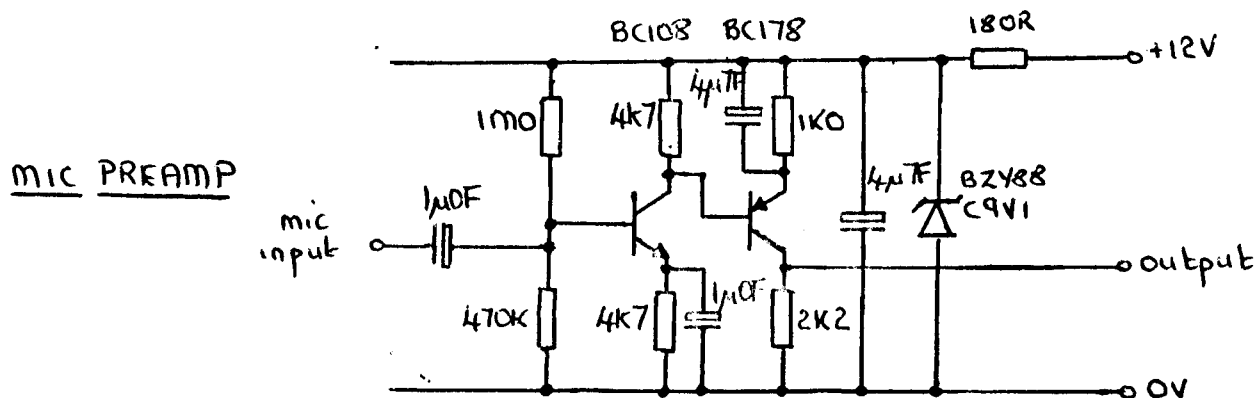

### Changeover System for 10 GHz NB

Apologies for an error in drawing the circuit of the changeover system last month. The 47R resistor across the 1K pot and 68R resistor should in fact be connected from the junction of the 68R resistor and the 1000p capacitor to earth. Also, the 384 MHz source should in fact be a 378.66 MHz source for a 2m IF.

### 9cm High Level Mixer

The following high level mixer is used by G8ADP on 9cm, producing 0.5W. The tuning elements are taken from the design by DCODA in VHF Comms P157, 3/1978, except the middle element is changed to solid brass, as is the element between D1 and D2 (for heatsinking). Reference should be made to the above article.

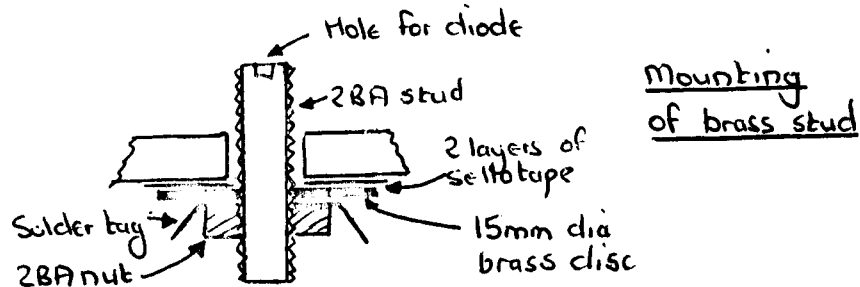
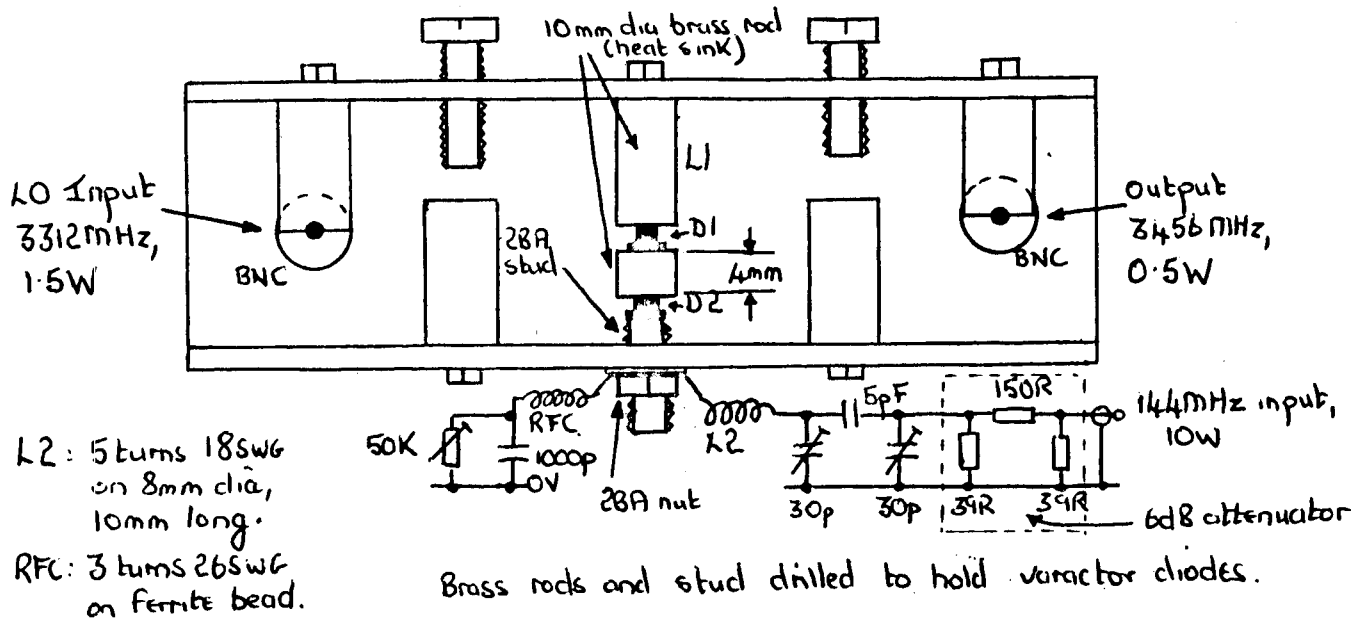

With 2.5W of 144 MHz and 1.5W of 3312 MHz a single diode (BXY27, 28, 39) produced little more than 100mW but a similar pair in series produced 500mW on 3456 MHz. By using a BXY39 for D1 and BXY28 for D2, Clive managed to obtain as much as 900mW out of the mixer.

The attenuator on the 144 MHz input is essential to isolate the 2m rig from the mixer, and makes tuning up much easier (most rigs will produce 10W so the attenuator would be needed anyway). The trimmers interact and a moderate amount of care is needed when tuning up - Clive suggests tuning up with half power input on 2m, then gradually increasing it to the full level. The 3312 MHz level was measured as 23dB down on the 3456 MHz level.

The local oscillator was generated from an 1104 MHz tripler. Initially an interdigital filter was used between this and the mixer to filter out the 2nd harmonic (2208 MHz), but later dispensed with, with no adverse effects. Care is needed to ensure that noise is not emitted by the diodes and picked up by the receiver if the local oscillator is fed to the tripler continuously - this can be minimised by adjustment of the 50k pot, then readjusting the trimmers for maximum output again.

06/04/81

## 2nd Cumulative Activity List

Call	Telephone	Sites, Times of Operation and Equipment
G3AYJ	021-356-0351W 021-354-5783H	Titterstone Clee, Salop, SO601771, 10G wb, nb, all day
G3BNL		Cleeve Hill, Gloucs, SO997246, 10G and 24G nb
G3FYX	0454-778288	Charterhouse, Somerset, ST498568, 10GHz wb, nbfm (phase mod) & nbcw, 24GHz wbfm .
G3JVL	07016-4482	Hayling Island, Hants, SZ710992, wb, nb, 10GHZ
G3PFR	0928-88427	Long Mynd SO46396, 7 Merryton Low SK028595, or Winter Hill SD647088, wx dependent. 10G wb, possibly nbfm or fsk.
G3YGF	0865-59988x348	Lacey Green, Bucks, SP820010, 10G nb,wb, 24Gwb?
G3YJH	021-262-4979wk 054-33-4280	Titterstone Clee, Salop, SO601771, all day, 10G wb and nb
G3WDG	0327-802100	Cleeve Hill, Gloucs, SO997246, 10G wb & nb.
G3ZIV	0757-638503	Merryton Low, Staffs, SK028595 wb 10G and 24G
G4CNV	0794-517691 0794-515222x370	Hardy's monument, Dorset, SY614876, 10G wb,nb, 24G wb
G4KGC	0327-802100	Cleeve Hill, Gloucs, SO997246, 10G nb
G4KNZ	0344-23200	Lacey Green, Bucks, SP820010, 10G nb, 24G wb
G8ADP	0420-62316	Upper Wield, Hants (home), SU634388, 10G 2W nb
G8AGN		Merryton Low, Staffs, 10G 40mW wb, 30" dish
G8PNL		Long Mynd SO46396, 7 Merryton Low SK028595, or Winter Hill SD647088, wx dependent, 10G wbfm.
G8FWA		16k N Leicester, SK460132, 10G wb & nb.
G8SHF		Bloreng, Gwent, SO270188, wb 10G and 24G
GW3PPF	via GW3NBK	SE Wales, 10GHz wbF2 F3, nb A1 F3, 24GHz wbF2 F3 Talkback S15, SU8, SM23, FM only.
GW3NBK	0222-60694	SE Wales with GW3PPF.

NB. wb=wideband, nb= narrowband equipment. Please inform us of any corrections to the above data.